



Estate Office



(0)91-294-2471900

UNIVERSITY ENGINEER

Nirman Bhawan

SPECIAL CONDITION OF TENDER (L.T. No. 2/1)

- (1)
- (a) Name of work:- **Providing Furniture etc at Establishment Section UAO**
- (b) Name of Contractor:-.....
- (c) Estimated Cost:- Rs.4,00,000/-
- (d) Amount of Earnest Money: @2% Rs.:- 8000/- @1/2%Rs.2000/-
- (e) Time & Date for receipt:-Time 11.00 AM Date: 14-08-2020
- (f) Time & Date for opening:-Time 12.30.00 PM Date : 25-08-2020
- (g) Site of work:- Establishment Section UAO
- (h) Period of completion:- 15 Days
- (i) Rate of Cement :-To be arranged by contractor (including 5% S.C.)
- (2) Sealed tenders are invited on percentage basis/item rates for the above work from the registered contractors of various departments which will be received & opened by the UNIVERSITY ENGINEER & the Tender Committee at the time & date shown respectively at Para 1 (e) & (f) in the presence of those contractors who wish to be present.
- (3) E.M. as shown in Para 1(d) above shall be deposited in Cash/Bank draft payable to the undersigned at Udaipur. No tender will be considered without E.M. Outstation Drafts will not be accepted.
- (4) Rates/tender premium quoted should be inclusive of all taxes and charges. No extra payment will be made for any tax Duty/Royalty/or other charge.
- (5) For the item of the works shown in 'G' schedule which have a reference to the B.S.R. of Rajasthan P.W.D. (B & R) in force on the date of opening of the tender of the relevant circle of P.W.D. shall be considered correct and applicable in the case of any discrepancy.
- (6) The contractor shall bind himself/themselves to carry out quantity upto 50% excess of each item the quantity mentioned in the 'G'/'H' schedule & 20% total contract value at the rate quoted by him/them in this tender according to the site requirement.
- (7) The contractor shall bind himself/themselves to carry out extra item of the G-Schedule as per clause 12& 12 A of agreement and total quantum 20% of the total contract value at the rate quoted by him/them in the tender according to the site requirement.
- (8) Work shall be done as per P.W.D. (B&R) Rajasthan Standard Specifications which may have been in force from time to time and measurements will be done accordingly.
- (9) Decision of the Vice-Chancellor, M.L.S.U.in matters of dispute shall be conclusive binding & final.
- (10) Contractors are supposed to see the site conditions and quarries and no claim for any lead other than the included in the rates of various items of works shall be entertained by University. The rate as shown against various items is complete and final.
- (11) Work shall be completed in all respects within the period of completion shown in Para 1(h) from the date of written order to commence the work.
- (12) For reasons beyond the control of the contractor, the University authorities may grant extension of the time for the time period as considered reasonable.

- (13) If the contractor fails to commence the work within a week of the receipt of the works order it shall rest, with the University to forfeit his earnest money.
- (14) Condition of any short except as provided in the printed form P.W.D. MF-54, amended upto date will be entertained. The condition in lieu with from P.W.D. MF-64, will be binding on the contractor.
- (15) Steel will not be supplied by the University.
- (16) Supply of cement, if available in the store, will be made at the rate shown in para 1(i) above.
- (17) The connection for water shall be obtained by the contractor from water works if the water is supplied by the University 1% of the gross amount of the bill will be recovered from all the bills.
- (18) The connection of electricity shall be obtained by the contractor from the AVVNL if electricity supplied by the University actual charges shall be recovered from all the bills.
- (19) Any conditional tender will be not accepted.
- (20) The offer shall remain valid for a period of Two months reckoned from the date of receipt of tender.
- (21) The tenders before submitting their terms and conditions (to executed the works must carefully go through the prescribed Contract Agreement) of the University successful tender shall be required to enter into an agreement with the University as per general conditions laid there in.
- (22) Contractors should sign on and put his seal each page of the tender document including terms and conditions incomplete tenders will be rejected.
- (23) The University reserves full rights to reject any or all tenders without assigning any reasons.
- (24) Disputes if any one subject of jurisdiction of the court at Udaipur only.
- (25) If there is any variations in general terms and conditions of the tender conditions of contract and special terms and conditions, then the provision in special terms and conditions shall prevail.
- (26) Annexure A to D Rajasthan transparency in Public procurement Act12 (see 7) Memorandum of Appeal are applicable.

UNIVERSITY ENGINEER

I accept the above conditions and beg to tender.....%Above/Below
on the 'G' schedule and as per 'H' schedule attached.

SIGNATURE OF THE CONTRACTOR
(With full address)

UNIVERSITY ENGINEER



Nirman Bhawan

"H" SCHEDULE (L.T. No. 2/1- 2020)

Name of work: - Providing Furniture etc at Establishment Section UAO

Issued to contractor:.....

(ITEM RATE)

S.No.	Particulars	Qty.	Unit	Rate/Per	Amount
1.	Supply of table of size 72"x30"x30" made of 18mm ply ISI mark & 1mm sunmica sheet of approved colour & shade with 3 drawers having single key lock system with inner face duco painting etc.as per the drawing inclosed.	9	Nos	Rs..... Each	Rs.....
2.	Supply of side runner cum computer table of size 48"x18"x30" with keyboard trolley in ply with one drawer having sunmica of approved colour & shade etc.as per the drawing inclosed.	9	Nos	Rs..... Each	Rs.....
	Note:- (i) Quantities of item may increase or decrease as per Site requirement. (ii) Any item may be deleted. (iii) The lowest bidder will be calculated by treating all item as complete job work.				
	TOTAL Rs.				

UNIVERSITY ENGINEER

I/We beg to tender as per Item Rate quoted on the “H” Schedule.

Signature of contractor

Name of contractor:.....

Address:.....

.....

Phone No. (M)..... **(O)**..... **(R)**.....

E-mail..... **PAN NO**.....

UNIVERSITY ENGINEER

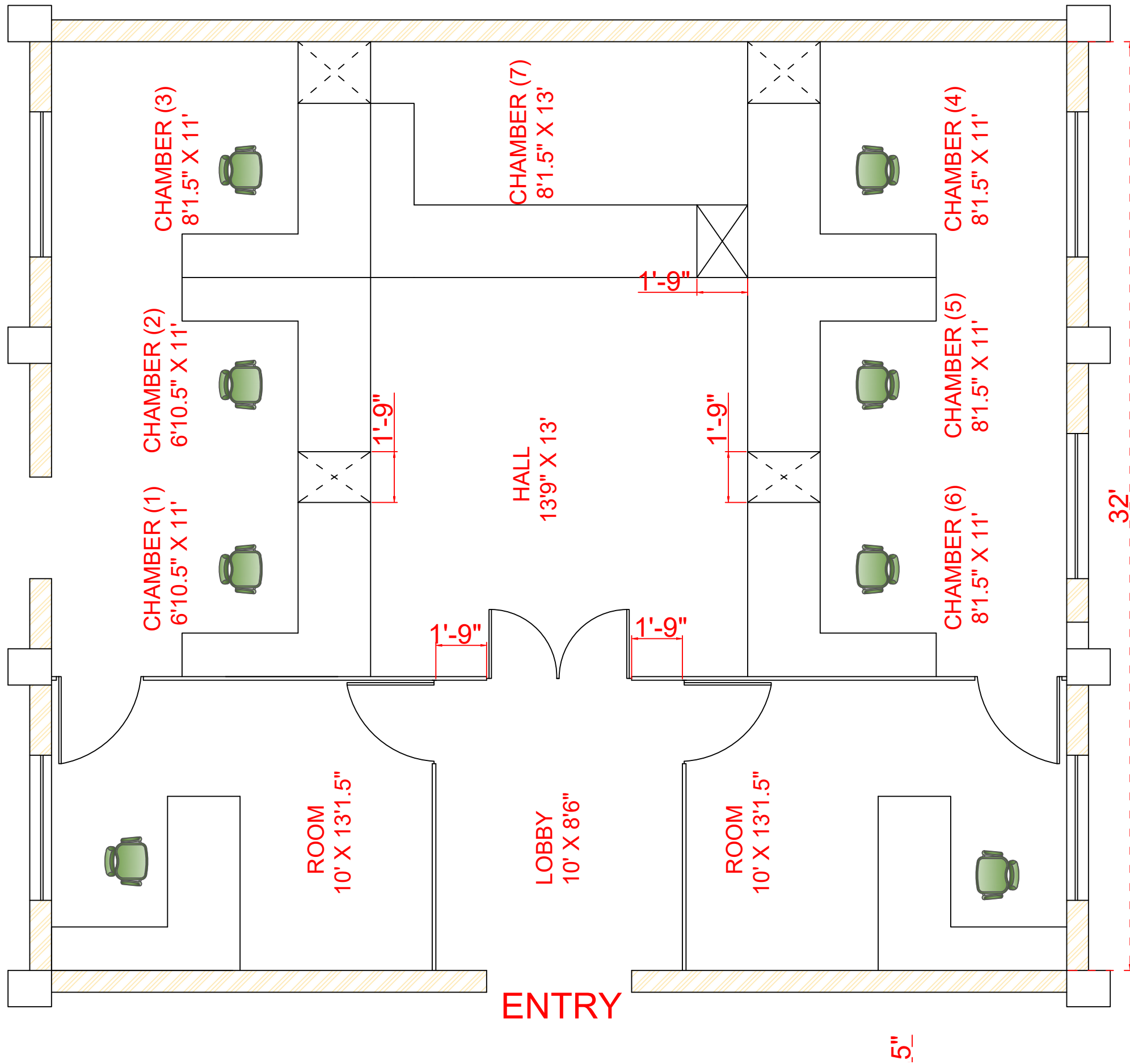

PROJECT:-	CORPORATE OFFICE	
CLIENT:-	KISHAN JI	
DRAWING TITLE:-	PLAN GROUND FLOOR (WEST FACING)	
CHECKED BY:-	MADAN LAL SUTHAR	
DESIGN BY:-	MADAN LAL SUTHAR	
DRAWN BY:-	ROHIT SUTHAR	
DATE:-	02/06/2020	
PROJECT CONSULTANTS	<p>Best Interior Designer & Civil Designer</p> <p>7-B ARDASH NAGAR, SOUTH SUNDERWAS, UDAIPUR cont.: 9414157199 (M) email: madhanlalsuthar@gmail.com, rohithsuthar@gmail.com</p>	

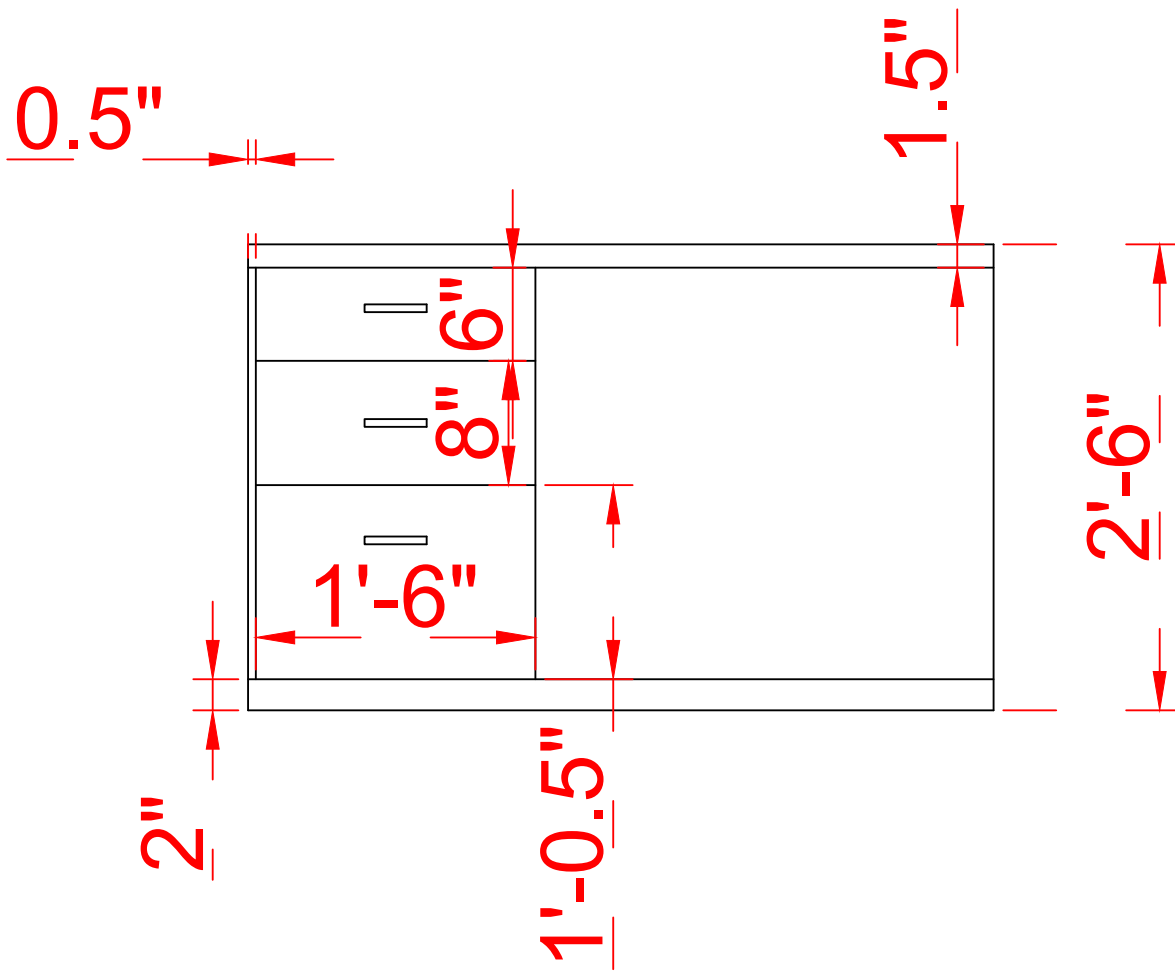

TABLE SIDE RUNNER

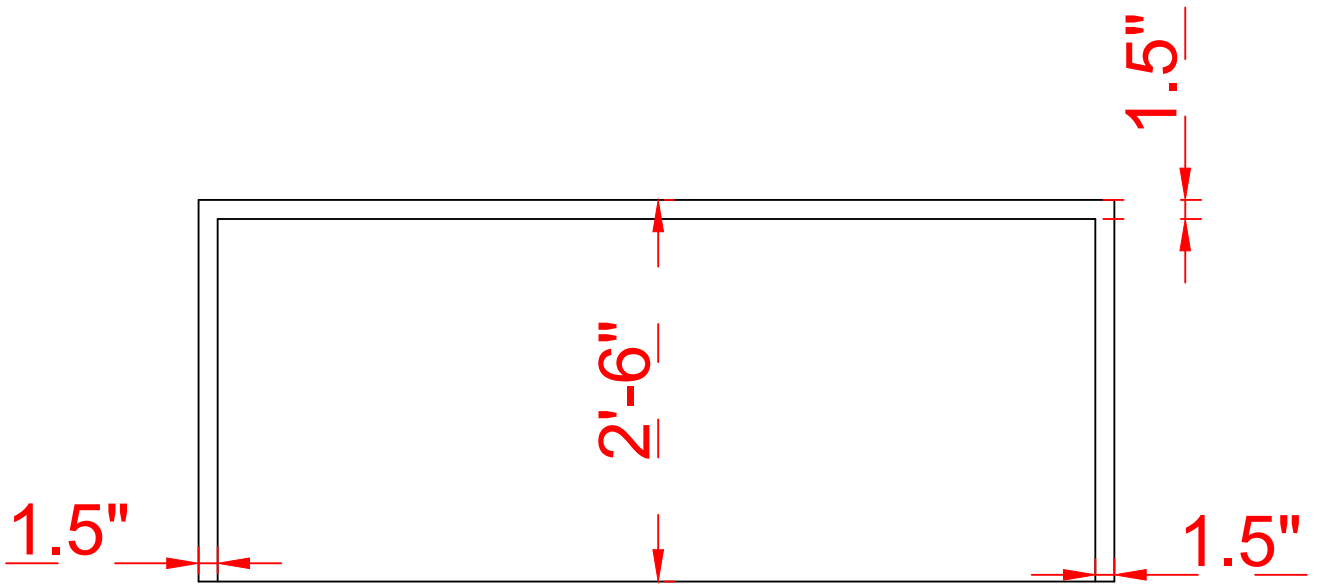

TABLE FRONT

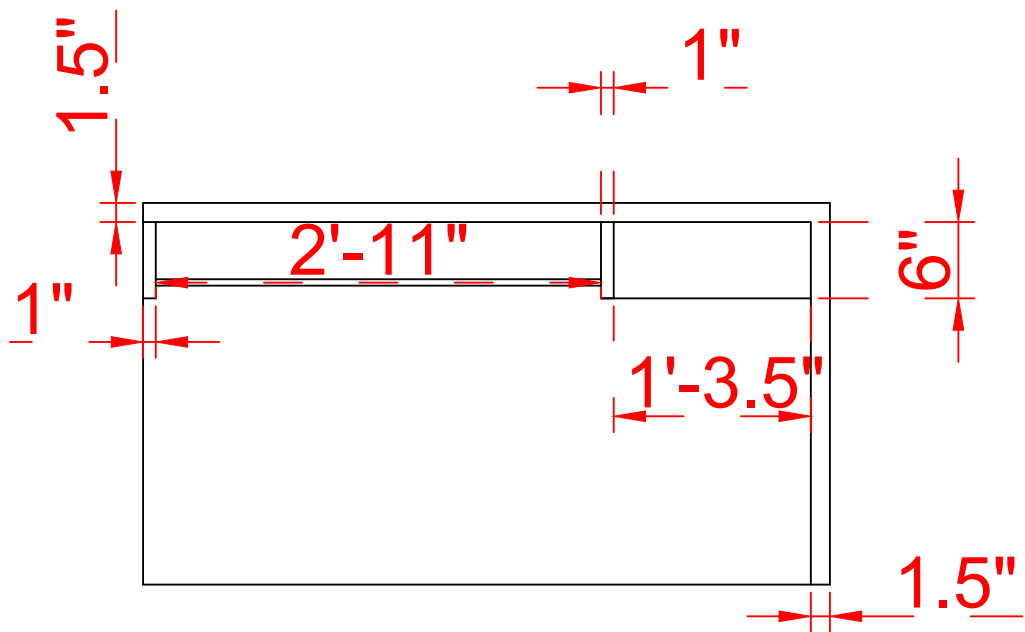

TABLE INNER SIDE

TABLE TOP

